

Kährs

Woodloc® Glue-Down Installation 7mm, 10mm, 14mm, 15mm

Table of Contents

<u>Jobsite</u>	
Subfloor Preparation	2 - 5
Underlayment	6
<u>Layout</u>	
Calculation Worksheet for Min. Board Width (U.S. Std.)	7
Calculation Worksheet for Min. Board Width (Metric)	8
<u>Tools & Techniques</u>	
Important Installation Notes	9
Kährs Product Key	10-11
Adhesive Tack and Open Time	11
Woodloc® Glue-Down Installation 7mm, 10mm, 14mm, 15mm	12-16
<u>Follow Up</u>	
Recoating Your Floor	17

Approved Commercial Uses

Kährs flooring may be used as a floor covering in public or private business, educational or religious buildings and offices.

Installation in any and all areas where food or drinks are consumed, or areas contiguous to outside entrances must be coated with a compatible wood finish urethane, in accordance with the finish manufacturers application procedures. Kährs recommends Bona Kemi or Bona Traffic in these cases. Contact Bona Kemi for details (www.bona.com).

Kährs does not warranty the performance of any site-applied finish. Please contact the finish manufacturer for suitable products, procedures, and warranty.

Maintenance

See Kährs Commercial Flooring Maintenance Procedures (Kährs Commercial Warranty) for maintenance details (available at www.kahrs.com).

For prefinished oiled floors, please refer to Natural Oiled Floors Maintenance and Renovation Procedures at www.kahrs.com

Subfloor Preparation

Note: *Warranty coverage may be lost due to failure to strictly follow all installation instructions and recommendations and/or the use of improper materials or tools.*
READ ALL INSTRUCTIONS CAREFULLY!

Subfloor Specifications

- A. The surface of the subfloor must be level to within 1/8" in an 8ft. radius. Check this by using the edge of a Kährs or Linnea plank to find high/low spots. To fill excessive voids or variations in the subfloor, use leveling compounds approved for your application. Consult the compound manufacturer to be sure it is appropriate. Allow the compound to dry thoroughly before beginning wood floor installation. Fifteen-pound felt or roofing paper is also appropriate to level a floor for a float-in installation. Cut small pieces to fit the shape of the depression and then stack as many sheets as necessary to level the area. DO NOT use this method to correct extensive variations in concrete subfloors.
- B. **You must** test concrete subfloors prior to installation by one of the following methods. Concrete subfloors must not contain more than 3 lbs. moisture on a dry-weight basis (calcium chloride test). Subfloor must read 4.5 or less with Tramex meter. Follow ASTM2170 - subfloor relative humidity not to exceed 75% with in-situ probe. Moisture content of wood subfloors must be less than 12% Moisture Content (MC). Document and keep ALL test results. Subsequent excessive moisture after pre-installation documented testing is evidence of moisture intrusion and will not be covered under Kährs warranty.
- C. The subfloor must be clean.
- D. Relative humidity at the job site must be, and remain, minimum 30%, maximum 60%. Temperature setting must be, and remain, within 15° F of normal operating range.

Evaluation

Before installing a Kährs floor, inspect the job site thoroughly. With the help of the Installation Environment Chart determine if grade, subfloor, and subfloor conditions are acceptable for the installation method you plan to use.

Exterior: Carefully inspect the outside surroundings for improper drainage and predictable or obvious sources of moisture. The yard should be graded (at least 6" in 10 ft.) to slope away from the foundation. Be sure that gutters and eaves sufficiently prevent rain from penetrating the foundation.

Under the house: In homes with crawl space or pier-beam foundations, foundation vents must provide cross-ventilation with no dead air space. Vents should be located throughout the foundation with opening area equal to 1-1/2% of the square-foot area within the crawl space (eg. a 1000sq. ft. crawl space must have 15 sq. ft. of vents that remain open all year). If excessive moisture exists underneath the house, you must lay a 6 mil black polyethylene moisture barrier on the ground in the crawl space below the installation area.

Interior: Check the moisture content of the subfloor. See item "B" above as well as "Moisture" at the end of this section. Room conditions can also indicate high moisture and relative humidity. Look for water stains, peeled paint near windows and doors, and rusty metal, especially nails.

Preparation

Wood Subfloors: Moisture Content (MC) must be less than 12%. To prepare the subfloor for installation, re nail any loose areas with squeaks. Sand or plane any high spots and fill any low areas. The subfloor should not vary more than 1/8" in an 8' radius. Check this by using the edge of a Kährs or Linnea plank to find any high or low spots. See Installation Environmental Chart for Approved Subfloors.

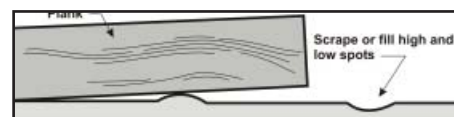

Subfloor Preparation

Preparation (con't.)

Preferred Subflooring: 3/4" (23/32", 18.3 mm) CDX grade plywood subfloor/underlayment (Exposure 1) 4' x 8' sheets OR 3/4" (23/32" 18.3mm) OSB subfloor/underlayment grade, with joint spacing 19.2" (475mm) on center joint construction or less. Direct Glue-Down installations: 2 layers 1/2" (11.9mm) CDX plywood.

Minimum Subflooring: 5/8" (19/32", 15.2mm) CDX plywood subfloor/underlayment (Exposure 1) 4' x 8' sheets, maximum 16" (400mm) on center joint construction. Direct Glue-Down installations: 2 layers 3/8" (10mm) CDX plywood.

Follow panel manufacturer recommendations for spacing and fastening. Typical panel spacing for joint systems is 1/8" (3.2mm) around perimeter and fastened every 6" (150mm) on bearing edges and every 12" (300mm) along intermediate supports.

Door casings should be notched or undercut to avoid difficult scribe cuts.

If nailing the floor, (Kährs 14, 15, 20 mm Traditional Tongue & Groove only) we suggest you cover the sub floor with 15 lbs. or higher asphalt felt or rosin paper to retard moisture and to help alleviate variations in the subfloor.

Concrete Subfloors: Lightweight (float-in only) and standard-density (float-in and glue-down) concrete subfloors are ideal applications for a Kährs floor. Concrete subfloors are generally acceptable for float-in installation if the subfloor appears to be dry (i.e. no standing water or discoloration of concrete) and Kährs Combo System Underlayment is used and installed properly. Be sure that, as a minimum, any concrete subfloor is at least 50-60 days old before installing a wood floor over it.

Moisture

To curb the adverse effects moisture will have on a Kährs wood floor and to determine the source of moisture problems, use the following checklist:

1. Inspect the gutters, drains, and down spouts outside the house. Clear out any clogs caused by leaves, dirt, or other substances. Down spouts are designed to transport water away from a foundation.
2. Check the landscaping surrounding the home to be sure the yard is sloped away from the foundation (at least 6" in 10 ft.).
3. Check windows and doors for proper drainage and waterproof caulking.
4. Inspect concrete subfloor for cracks or buckling. Sometimes the water table (water beneath the surface) may rise and force water up through the concrete floor with hydrostatic pressure.
5. Check the ventilation system in the crawl space, basement, and attic. Moisture will collect on walls and floors if dead air (i.e. little or no ventilation) is present. As a rule, ventilation per sq. ft. should equal 1-1/2% of the sq. ft. of the area in question.
6. Inspect pipes, water heater tank, dishwasher, and any other plumbing fixtures in the affected area.
7. Remember to take seasonal changes in relative humidity into consideration when installing a Kährs floor.
8. Signs that the moisture content is too high include discolored (darker) concrete and evidence of actual water droplets.

Subfloor Preparation

Moisture (con't.)

Required moisture testing for ALL Kährs radiant heat installations and direct glue-down flooring:

Calcium Chloride test with a reading of 3 lbs. or less on a dry weight basis (2 lbs. or less for Radiant Heat Installations). Testing kits are generally available through your distributor or call the NFWA at 800-422-4556 (or 800-848-8824 in Canada) for the source nearest you. Follow test kit manufacturer's instructions for conducting test and measuring results. If calcium chloride results read over 3 lbs. but does not exceed 8 lbs. (and no obvious source of the moisture can be eliminated) you must use either of the following approved moisture sealers before installing the floor for the **Kährs Moisture Protection Warranty to apply:**

Warranty to apply:

- DriTac MCS 7000 when used with DriTac 7600 or 7500 Adhesive (call 800-394-9310 for source nearest to you).
- Dependable Cutdown (call 800-227-3434 for the source nearest you).
- Concrete Moisture Barrier System*

* If moisture is present an alternative is a barrier of inexpensive sheet vinyl or "slip sheet" (PVC). Use the manufacturers recommended adhesive for a full spread application to completely adhere the vinyl to the subfloor. Since Kährs cannot guarantee the bond of the vinyl to the subfloor, or subsequent performance of the vinyl, a patch test is strongly advised. Install several 3" x 3" pieces of vinyl in different areas of the installation. Wait 72 hours. Remove the vinyl. If the backing remains attached to the concrete, the subfloor should be acceptable for full spread vinyl installation.

Note: These concrete sealers are **NOT** approved for Radiant Heat installations.

All concrete sealer/vinyl manufacturer testing, documentation, and installation requirements **MUST** be followed for Kährs Limited Warranty to apply.

Other Subfloors: Kährs floors can be installed directly over some existing floors (i.e. vinyl and rubber tile, steel plates, terrazzo, and existing wood floors). The subfloor or existing floor must meet the requirements listed in "Subfloor Specifications." A Kährs floor installed over existing floors must be installed with the float-in method.

Installation Environment Chart			
I. Grade Type	Glue**	Nail*	Float
A. Above Grade	yes	yes	yes
B. On Grade	yes	yes	yes
C. Below Grade	no	no	yes
D. Over Radiant Subfloor	no	no	yes
II. Subfloor Type	Glue**	Nail*	Float
A. Concrete (701 lbs. cu. ft. density or higher)	yes	no	yes
B. Light-weight concrete	no	no	yes
C. Association-grade underlayment plywood	yes	yes	yes
D. Association-grade underlayment particle board	yes	no	yes
E. Stamped Underlayment Grade OSB (Oriented Strand Board)	yes	yes	yes
F. Old wood floors - above grade only	no	no	yes
(next page)			

Subfloor Preparation

Installation Environment Chart			
II. Subfloor Type (con't.)	Glue	Nail*	Float
G. Asphalt tile	no	no	yes
H. Inlaid linoleum	***	no	yes
I. Vinyl asbestos tile	no	no	yes
J. Cushion vinyl	no	no	yes
K. Rubber tile	no	no	yes
L. Solid vinyl tile	no	no	yes
M. Steel	no	no	yes
N. Marble	no	no	yes
O. Ceramic	no	no	yes
P. Carpet	no	no	no
*14mm, 15mm, 20mm T & G only			

*** Check Kährs Technical Services Department: 1-800-ASK-KAHR

Underlayment

Kährs QuietStride:

1. *Direct Glue-Down*: Install QuietStride wall to wall, butt all seams together (do not tape seams), directly adhering to subfloor with QuietStride Adhesive* or a premium multi-purpose adhesive. Fully adhere Kährs flooring to underlayment using approved adhesive and trowel (see *Glue-Down Installation* for details). **Note**: an approved concrete sealer must be used if calcium chloride test exceeds 3lbs. for Kährs Moisture Protection Warranty to apply.
2. *Direct Glue-Down over "float-in" underlayment*: First install 6 mil polyethylene plastic loose-laid, seams over-lapped 8". Run plastic up wall 2" (trim excess after installation, before installing trim). Loose-lay QuietStride on top of plastic, wall to wall, butt all seams together (do not tape seams). Fully adhere Kährs flooring to underlayment using approved adhesive and trowel (see *Glue-Down Installation* for details). **Note**: an approved concrete sealer must be used if calcium chloride test exceeds 3lbs. for Kährs Moisture Protection Warranty to apply.

* **QuietStride Adhesive** has been developed for adhering QuietStride Underlayment directly to the subfloor for use in "double-stick" installations. The adhesive is a quick, inexpensive technique for affixing QuietStride Underlayment to the subfloor, then gluing the Kährs flooring to the QuietStride Underlayment with one of the approved Kährs wood flooring adhesives.

- QuietStride Adhesive product ID #710248
- Sold in 1gallon pails

Important: Kährs does not guarantee the performance of any non-Kährs branded underlayment.

Calculation Worksheet for Min. Board Width - (U.S. Std.)

Purpose: To ensure last board of the installation (or long board at an obstruction) is not too narrow.
General Rule: Kährs requires that no board have a width less than 3" or .38" of a full board width.
Notes on Equation: This rule applies to boards with an original thickness of 5/8" x 3-strip wide. This equation should be used when a board 4' or more in length meets an obstruction.

WORKSHEET

Step 1
Measure width of connected area* from starting wall to finish wall or obstruction, in inches. Round to the nearest 1/4".

Connected Area Width in inches with fraction: _____

Step 2
Convert "inches with Fraction" to "Inches with Decimal". Use conversion chart below.

Connected Area Width in inches with decimal: _____

Step 3
Multiply "Required Expansion Space" by 2. Use chart below.
 Total Expansion Needed from above: _____

Connected Area Width (from Step 2)	Expansion Space	Total
Under 144"	1/4" x 2 =	.50"
144" - 288"	1/2" x 2 =	1.0"
288" - 480"	3/4" x 2 =	1.5"

Step 4
Subtract Total Expansion Needed from Connected Area Width to determine Actual Floor Width.

Total from Step 2: _____"
 Total from Step 3: - _____"
 Actual Floor Width in inches with decimal: = _____"

Step 5
Determine total # of rows of flooring needed.

Actual Floor Width (Step 4): _____"
 Board Width in Decimal - measure board and use chart below to convert: ÷ _____"
 Total Rows of Flooring: = _____ rows

Step 6
If the result in Step 6 contains a decimal less than .38", you must rip the starting row in half to ensure proper width of the last row.

EXAMPLE

Step 1
Measure width of connected area* from starting wall to finish wall or obstruction, in inches. Round to the nearest 1/4".

Connected Area Width in inches with fraction: _____ 325-1/4"

Step 2
Convert "inches with Fraction" to "Inches with Decimal". Use conversion chart below.

Connected Area Width in inches with decimal: _____ 325.25"

Step 3
Multiply Required Expansion Space by 2. Use chart below.
 Total Expansion Needed from above: _____ 1.5"

Connected Area Width (from Step 2)	Expansion Space	Total
Under 144"	1/4" x 2 =	.50"
144" - 288"	1/2" x 2 =	1.0"
288" - 480"	3/4" x 2 =	1.5"

Step 4
Subtract Total Expansion Needed from Connected Area Width to determine Actual Floor Width.

Total from Step 2: _____ 325.25"
 Total from Step 3: - _____ 1.50"
 Actual Floor Width in inches with decimal: = _____ 323.75"

Step 5
Determine total # of rows of flooring needed.

Actual Floor Width (Step 4): _____ 323.75"
 Board Width in Decimal - measure board and use chart below to convert: ÷ 7.875"
 Total Rows of Flooring: = _____ 41.11 rows*

* The first board in this installation would be cut in half.

Step 6
If the result in Step 6 contains a decimal less than .38", you must rip the starting row in half to ensure proper width of the last row. Ripping the starting row in half will increase the last board width by .50 of a board. In this case the last board will end up being .61 of a board or approx. 5", instead of .11 or 1" wide.

*From Step 1 - Connected Area is defined as all areas connected without a break. If Room A and Room B both are to have flooring installed and are directly connected, or connected by a hallway, without a t-molding, the **connected area** is the width of both Room A and Room B, and the hallway (if applicable). Obstructions can include cabinets, islands, and the wall opposite the starting wall in the same room, if the flooring continues to another room without a break. Multiple calculations may need to be made to best determine the amount cut from the starting row.

Fraction	Decimal Equivalent
1/4"	.25"
1/2"	.50"
3/4"	.75"

Board Width	Decimal Equivalent
7-7/8"	7.875"
8-1/10"	8.100"

Calculation Worksheet for Minimum Board Width - (Metric)

Purpose: To ensure last board of the installation (or long board at an obstruction) is not too narrow.
General Rule: Kährs requires that no board have a width less than 76mm or .38" of a full board width.
Notes on Equation: This rule applies to boards with an original thickness of 15mm x 3-strip wide. This equation should be used when a board 120cm or more in length meets an obstruction.

WORKSHEET	
Step 1 Measure width of connected area* from starting wall to finish wall or obstruction, in inches. Round to the nearest 1/4".	
Total Area Width in mm:	_____
Step 2 Multiply Required Expansion Space by 2. Use chart below.	
Required Expansion Space:	_____mm
	X 2
Total Expansion =	_____mm
Step 3 Subtract Total Expansion from Total Area Width to determine Actual Floor Width.	
Total from Step 1:	_____mm
Total from Step 2:	- _____mm
Actual Floor Width:	= _____mm
Step 4 Determine total # of rows of flooring needed.	
Actual Floor Width (Step 3):	_____mm
Board Width. Measure board. It will be either 200 or 205mm.	÷ _____mm
Total Rows of Flooring:	= _____rows
Step 5 If the result in Step 6 contains a decimal less than .38", you must rip the starting row in half to ensure proper width of the last row.	

EXAMPLE	
Step 1 Measure width of connected area* from starting wall to finish wall or obstruction, in inches. Round to the nearest 1/4".	
Total Area Width in mm:	8262mm
Step 2 Multiply Required Expansion Space by 2. Use chart below.	
Required Expansion Space:	20mm
	X 2
Total Expansion =	40mm
Step 3 Subtract Total Expansion from Total Area Width to determine Actual Floor Width.	
Total from Step 1:	8262mm
Total from Step 2:	- 40mm
Actual Floor Width:	= 8222mm
Step 4 Determine total # of rows of flooring needed.	
Actual Floor Width (Step 3):	8222mm
Board Width. Measure board. It will be either 200 or 205mm.	÷ 200mm
Total Rows of Flooring:	= 41.11 rows*
<i>*The first board in this installation would be ripped in half.</i>	
Step 5 If the result in Step 6 contains a decimal less than .38", you must rip the starting row in half to ensure proper width of the last row. Ripping the starting row in half will increase the last board width by .50 of a board. In this case the last board will end up being .61 of a board or approx. 120mm, instead of .11 or 22mm wide.	

* From Step 1 - **Connected Area** is defined as all areas connected without a break. If Room **A** and Room **B** both are to have flooring installed and are directly connected, or connected by a hallway, without a t-molding, the **connected area** is the width of both Room **A** and Room **B**, and the hallway (if applicable). Obstructions can include cabinets, islands, and the wall opposite the starting wall in the same room, if the flooring continues to another room without a break. Multiple calculations may need to be made to best determine the amount cut from the starting row.

Important Installation Notes

Please see our website - www.kahrs.com for Kahrs Floor Care Guide and Lifetime Guarantee.

Installation

Glue down:

Installing Kährs floors with the Glue down method requires no expansion breaks in the floor and is not limited in size. A 1/2" gap at perimeter walls is required to allow engagement of last boards.

Adhesive Tape on Kahrs Floors

The use of adhesive tape on any Kährs floor for any reason (i.e. to fasten temporary protection) is not recommended and is not covered in our warranty.

Kährs Flooring is approved for installations in ½ bathrooms only (no bathrooms including showers or bath tubs)

Additional Finish Coating

For additional wear protection, a waterborne urethane finish is compatible with Kährs factory finishes. The following products from Bona Kemi are recommended:

- Pacific Strong
- Traffic

Contact Bona Kemi USA, Inc. (1-800-574-4674). Follow manufacturers instructions for recoating a prefinished wood floor. Kährs International, Inc. does not guarantee the performance and/or durability of these products.

Installation

Do you have the tools and products you need to install a Kahrs floor?

Never start a job unprepared! Each installation method requires different tools and products. Use the chart below to be sure you are fully prepared to begin your installation. For your convenience, product codes (SKU's) are listed next to each Kährs product name. Where appropriate, square footage and other important information is included as well.

KAHRS PRODUCT KEY (LISTED BY INSTALLATION METHOD)						
Product/Material	SKU	Float In	Radiant Heat	Glue Down	Nail Down	
Kährs 20mm Flooring - Tongue & Groove	Various	Yes	Yes	Yes	Yes	
Kährs 15mm Flooring - Woodloc	Various	Yes	Yes	Yes	No	
Kährs 15mm Flooring - Tongue & Groove	Various	Yes	Yes	Yes	Yes	
Kährs 14mm Flooring - Tongue & Groove	Various	Yes	Yes	Yes	Yes	
Kährs 14mm Flooring - Woodloc	Various	Yes	Yes	Yes	No	
Kährs 11mm Flooring - Tongue & Groove	Various	No	No	Yes	Yes	
Kährs 10mm Flooring - Woodloc	Various	Yes	Yes	Yes	No	
Kährs 7mm Flooring - Woodloc	Various	Yes	Yes	Yes	No	
Combo System Underlayment (subfloor)	710730CSU	Yes	Yes	No	Tar/Roofing	
QuietStride Underlayment	710113	Yes	Yes	Yes	No	
QuietStride Adhesive	710248	No	No	Yes	No	
Prefinished Moldings	Various	Yes	Yes	Yes	Yes	
Landobond Adhesive; 239 sq.ft. per bottle	710225	Yes	Yes	Yes	Yes	
Woodloc 5S Lock/Unlock Tool	710559	Yes	Yes	Yes	Yes	
Knocking Block, T & G Float-In and Nail-Down, 14, 15mm	710202	Yes	Yes	No	Yes	
Knocking Block, T&G, Woodloc Glue-Down 14mm &15mm	710281	No	No	Yes	No	
Knocking Block, Glue Down 11mm	710290	No	No	Yes	No	
Woodloc Hand Block (Woodloc only)	710266	Yes	Yes	No	No	
Woodloc Installation Wedge (Woodloc only)	710267	Yes	Yes	No	No	
Last Board Puller (Jemmy)	710203	Yes	Yes	Yes	Yes	
Nail Plate Adapter 15mm for use with Bostitch Mach III	710268	No	No	No	Yes	
Nail Plate Adapter 14, 15mm for use with Bostitch Mach III	710269	No	No	No	Yes	
Expansion Shims	710283	Yes	Yes	Yes	Yes	
Recommended Mastic*** Taylor 2071, Dri Tac, Stauf	Various	No	No	Yes	No	

(continued next page)

* Tongue & Groove only

** Contact Kährs Customer Service

*** Alternative: any moisture cured urethane wood flooring adhesive. See Glue-Down sections for details.

KAHRS PRODUCT KEY (LISTED BY INSTALLATION METHOD)					
Product/Material	SKU	Float In	Radiant Heat	Glue Down	Nail Down
Spline - Kährs 11, 14, 15, 20 mm only - to change directions	**	Yes	Yes	Yes	Yes
Router Bit Kährs 11mm	710291S	Yes	Yes	Yes	Yes
Router Bit Kährs 14, 15mm	710291	Yes	Yes	Yes	Yes
Kährs Wood Cleaner	710280	Yes	Yes	Yes	Yes
Peel & Stick Floor Protectors	710287	Yes	Yes	Yes	Yes
Touch Up Kits	710273-79	Yes	Yes	Yes	Yes

Adhesive Tack and Open Times

Temperature/Relative Humidity Time Chart						
Temp.		Humidity				
		40%	50%	60%	70%	80%
60°	Tack	120 min.	110 min.	100 min.	90 min.	80 min.
	Open	3.5 hr.	3.5 hr.	3.5 hr.	3 hr.	3 hr.
65°	Tack	110 min.	100 min.	90 min.	80 min.	70 min.
	Open	3 hr.	3 hr.	3 hr.	3hr.	2.5 hr.
70°	Tack	100 min.	90 min.	80 min.	70 min.	60 min.
	Open	3 hr.	3 hr.	3hr.	2.5 hr.	2.5 hr.
75°	Tack	90 min.	80 min.	70 min.	60 min.	50 min.
	Open	3 hr.	2.5 hr.	2.5 hr.	2.5 hr.	2.5 hr.
80°	Tack	80 min.	70 min.	60 min.	50 min.	40 min.
	Open	3 hr.	2.5 hr.	2.5 hr.	2.5 hr.	2 hr.

Note: This chart is for reference only. Actual times may vary dramatically based on jobsite conditions.

Glue-Down Installation of Woodloc®

NOTE:

- **Kährs flooring is covered by a Limited Lifetime Warranty. However, warranty coverage may be lost due to failure to strictly follow all installation instructions and recommendations or the use of improper materials or tools. READ ALL INSTRUCTIONS CAREFULLY.**

IMPORTANT!

- **Do not open packages until ready to begin installation!** Inspect boards before installation. Kährs flooring is sealed at the factory with a 7% moisture content. Opening cartons to acclimate the flooring (as with some solid strip flooring) could result in a difficult installation.
- As an installer, it is your responsibility to be aware of the grade, Relative Humidity of the room, and moisture content of the subfloor. You should check that each plank is free of damage or manufacturing defects. Any unusable boards should be set aside for later replacement.
- Tip: Dry-lay first two rows to familiarize yourself with Woodloc™.

Prior to Installation

- See Jobsite/Subfloor Preparation section and follow all requirements before installation.
- Door casings should be notched or undercut to avoid difficult scribe cuts.
- Sweep or vacuum subfloor thoroughly.
- Approved and recommended adhesives are Taylor 2071 Tuff Lok X-Link Wood Flooring Adhesive, Taylor MS, DriTac 7600, 7500, 7400, 9200, and Stauf SMP940, WFR930, PUM950. Apply adhesive directly to subfloor @ rate of 50 sq. ft. per gallon. Use manufacturer's recommended trowel. **Note:** *Always wear rubber gloves when using adhesives!*
*Optional adhesive: any moisture-cured urethane wood floor adhesive. For other approved adhesives call 1-800-ASK-KAHR.

Tools and Materials Required

- Tape Measure
- Chalk Line
- Hammer
- Last Board Puller
- Glue-Down Knocking Block
- Taylor 2071 Tuff Lok X-Link Wood Flooring Adhesive, Taylor MS, DriTac 7600, 7500, 7400, 9200, and Stauf SMP940, WFR930, PUM950.
- Adhesive manufacturer's recommended trowel
- Expansion Shims
- Floor Protectors
- 100 lb. Roller

For SKU numbers see Kährs Product Key in Tools & Techniques, page 12, this Guide.

Glue-Down Installation of Woodloc®

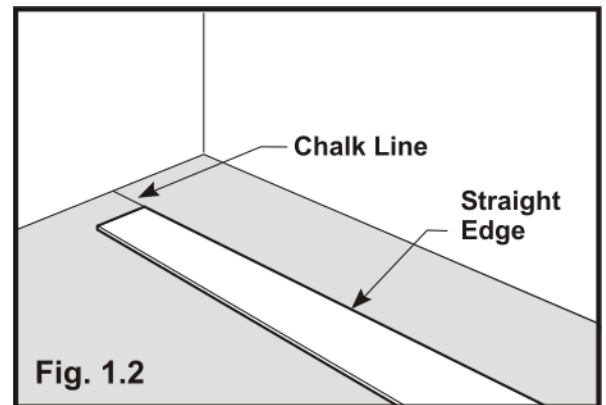
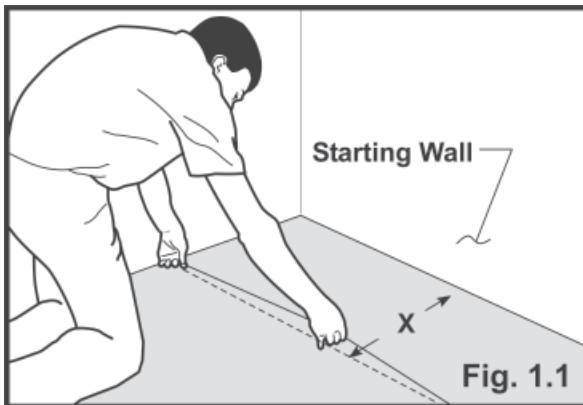

Step 1: Layout

- 1.1 Using starting wall as reference, snap chalk line on subfloor at distance X from wall as shown in Fig. 1.1. To calculate X, engage two boards together (refer to Step 2.1 on locking procedure) and measure total width, including exposed groove, then add 1/2".
- 1.2 Align straight edge (Kährs board or any solid material with straight edge) with chalk line and secure to subfloor.

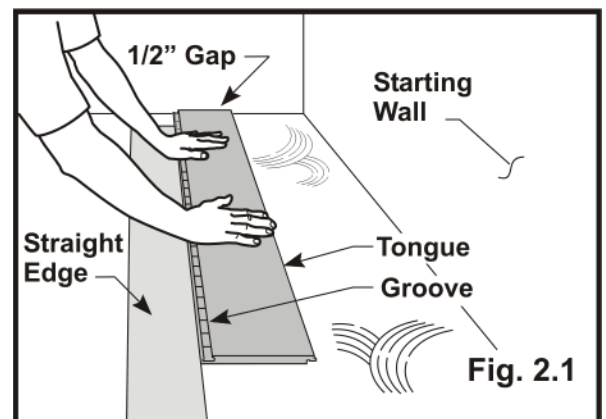
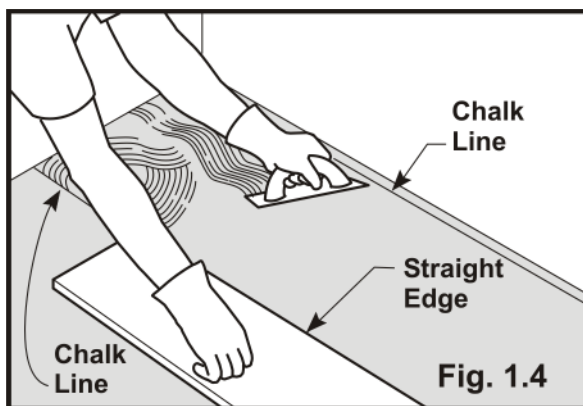

- 1.3 Measure 1/2" from starting wall and snap another chalk line (Fig. 1.4).
- 1.4 Spread adhesive in area between straight edge and second chalk line (Fig. 1.4). Use only as much adhesive as can be used during open time of adhesive.

Step 2: Installation

- 2.1 Start in corner with tongue sides facing walls and long groove side directly up against straight edge. Lay board into adhesive (Fig. 2.1). Remember to allow 1/2" expansion gap at wall.

Glue-Down Installation of Woodloc®

Step 2: Installation (con't.)

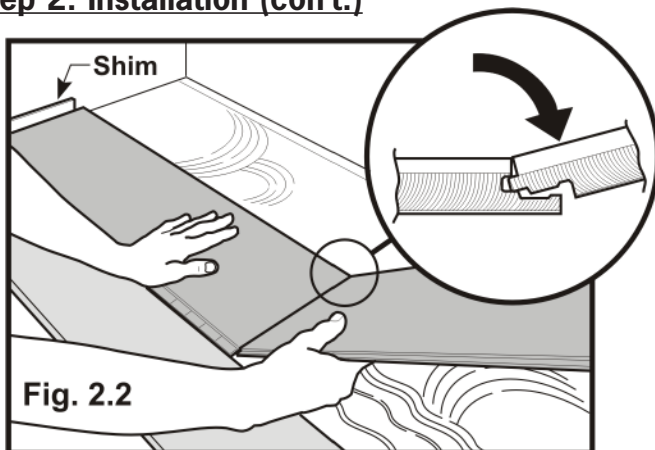

2.2 Hold next board against first board at approximate 45° angle and lay flat on floor as shown in Fig. 2.2. Continue in this manner for entire first row, allowing for 1/2" expansion gap. Insert shims at both ends.

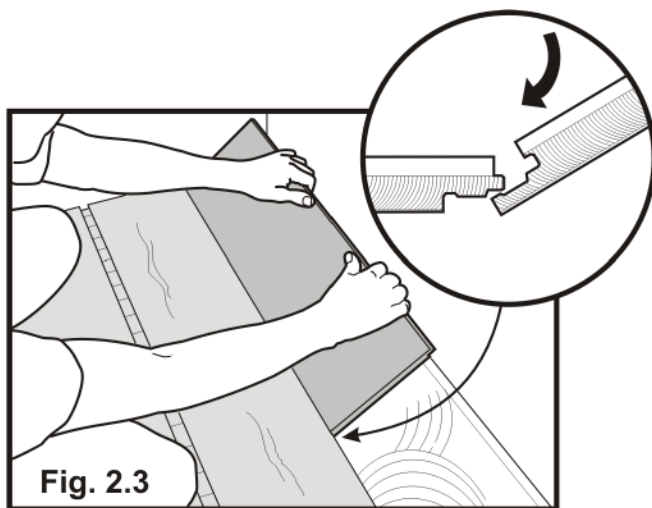

2.3 Use cut off from first row to start second row (Fig. 2.3). With groove side facing first row, hold board at approximate 45° angle and press inward, completely engaging long side joint. Ensure end joint stagger from row to row is a minimum of 20" for 14mm and 15mm and a minimum of 12" for 7mm and 10mm flooring.

2.4 Leave tongue side of board raised - **DO NOT** lay board flat into adhesive until all boards in row are fully engaged on long side.

2.5 Engage short end of next board as in Step 2.2 (Fig. 2.2). Lay long side in line with tongue of adjacent board in first row.

Glue-Down Installation of Woodloc®

Step 2: Installation (con't.)

2.6 Since last row will generally not fit perfectly, scribe the row and cut to fit, allowing 1/4" (minimum) for expansion gap (Fig. 2.6a). Close seam tightly by pressing board against adjacent board. If necessary, use Last Board Puller (sku 710203) to assist with engagement (Fig. 2.6b). Continue until row is complete.

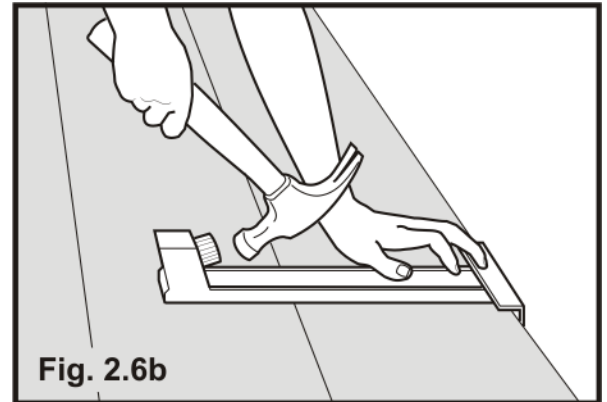
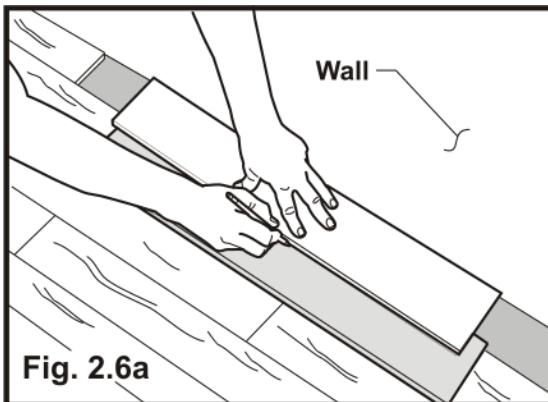

2.7 After first two rows are installed, ensure expansion gap between boards and walls are shimmed securely (Fig. 2.7, below). If recommended by adhesive manufacturer, roll flooring with 100 lb. roller to ensure contact between flooring and subfloor. Place weight (e.g., unopened cartons) along perimeters until adhesive sets up. Remove straight edge.

Step 3: Subsequent Rows

3.1 Once starting rows are firmly in place, apply adhesive in a "wet lay" method. Do not apply more adhesive than can be used within open time of adhesive. Immediately place flooring in "wet" adhesive and proceed with installation (Fig. 3.1).

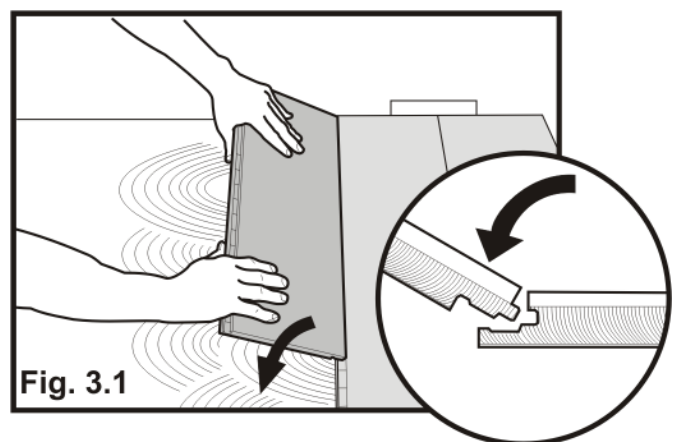
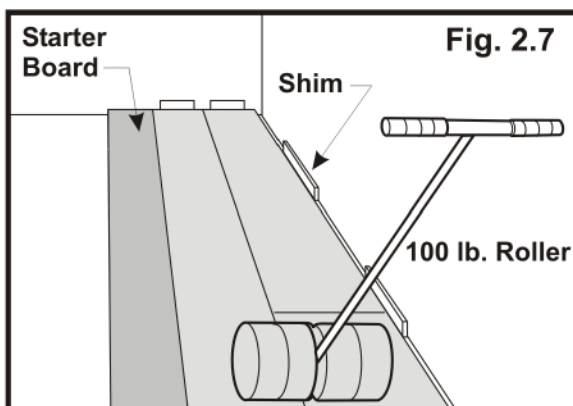

Glue-Down Installation of Woodloc®

3: Subsequent Step Rows (con't.)

- 3.2 Start each row with cut off end of last board from previous row (Fig. 3.1).
- 3.3 **DO NOT** lay board flat into adhesive until all boards in row are fully engaged. To assist in engaging, use Woodloc™ Glue-Down Knocking Block (sku 710281) to engage long joints, as shown in Fig. 3.3.

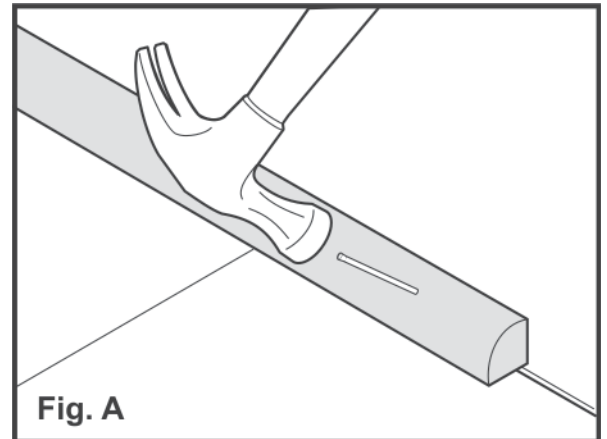
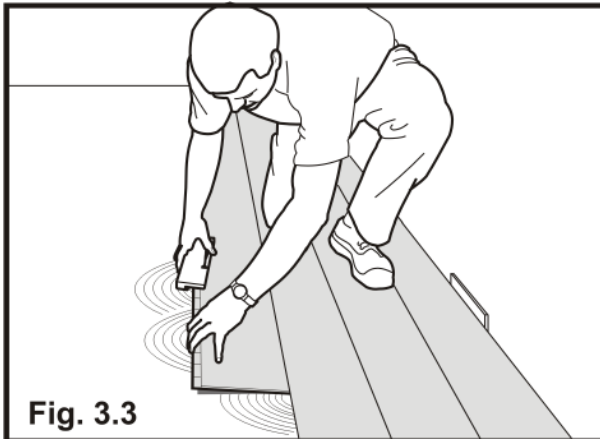

Tips:

- After first three rows are laid, have one installer work on installing flooring while others spread adhesive and cut boards as needed.
- Installation of Woodloc® is easier while working on already installed flooring, as shown in Fig. 3.3.
- Working in this manner lessens chance of accidentally transferring adhesive onto flooring surface, thereby reducing clean-up time.
- For doorway installation instructions, see Woodloc® 15mm Float-In instructions.

After Installation

- Remove expansion shims and use required Kährs moldings and/or trim pieces to cover expansion space (Fig. A).

Clean Up

- Immediately clean any adhesive spilled on wood flooring during installation. Follow adhesive manufacturer's recommendations.
- Removal of cured adhesive from skin, tools, and equipment is difficult. Consult manufacturer for cleaning procedure. **Tip:** cover areas of trowel not used to spread adhesive with silver duct tape. After use, simply tear off tape and clean exposed areas with mineral spirits.

Curing

- Keep foot traffic to absolute minimum until adhesive is fully cured (follow mfg.'s recommendations).
- Wait at least 24 hrs. before placing furniture back in room and resuming normal traffic.

Maintenance

- Clean floor using dry dust mop or damp (lightly misted or well rung out) mop or cloth. Regularly use Kährs Wood Floor Cleaner for best results. Do not use oil soap or water-emulsion, self polishing waxes. **NEVER** wet mop floor. Place Steel-shank or Peel & Stick Floor Protectors on furniture legs to prevent damage. See Kährs Floor Care Guide & Lifetime Guarantee for full details (available at www.kahrs.com).

Recoating your Kährs Floor

Kährs floors can be renewed without removing the factory finish. As a floor ages, normal wear and tear will cause a floor to lose its luster. This is natural - it happens to all wood floors. To renew the luster and extend the wear layer of the Kährs floor, recoat with water based urethane coating.

Recoating should be done when necessary. Don't wait until the finish has worn down. Call your professional flooring contractor for recommendations as soon as you see a wear pattern developing.

Preparation:

Whether coating a floor upon installation or at a later date when it begins to show wear, the following recoating procedures are recommended:

1. Kährs recommends the BonaTech® Prep chemical bonding system for recoating all Kährs floor. Please contact Bona Kemi USA @ 1-800-574-4674 for product information, directions, and qualified professionals in your area.
2. Do not use water based urethane over a floor that has been waxed or oiled. If unsure, wipe a small section of the floor with a white rag dampened with mineral spirits to test for wax or coat a test area to check adhesion prior to coating the entire floor. It is imperative, regardless of the age of the floor, to test for adhesion.

Application:

Application of a waterborne finish should be done according to instructions on the product label. Important factors to consider with any urethane are:

- Shake or Stir Bottle: There will also be a sitting time to consider before using.
- Coverage/Feet per Gallon : This will dictate how heavy or thin the finish is designed to be applied.
- Dry Time: Average time before a finish can be recoated.
- Curing Time: This includes time before a floor is walked on, time before normal use, and complete cure time.

Note: To achieve a uniform look, coat the worn traffic areas first, followed by a coat over the entire floor.

Recommended finishes from Bona Kemi:

- Pacific Strong
- Traffic

Call Kährs Technical Line (1-800-ASK-KAHR) for other compatible floor finishes.

Note: For prefinished oiled floors please refer to Natural Oiled Floors Maintenance and Renovation Procedures at www.kahrs.com